

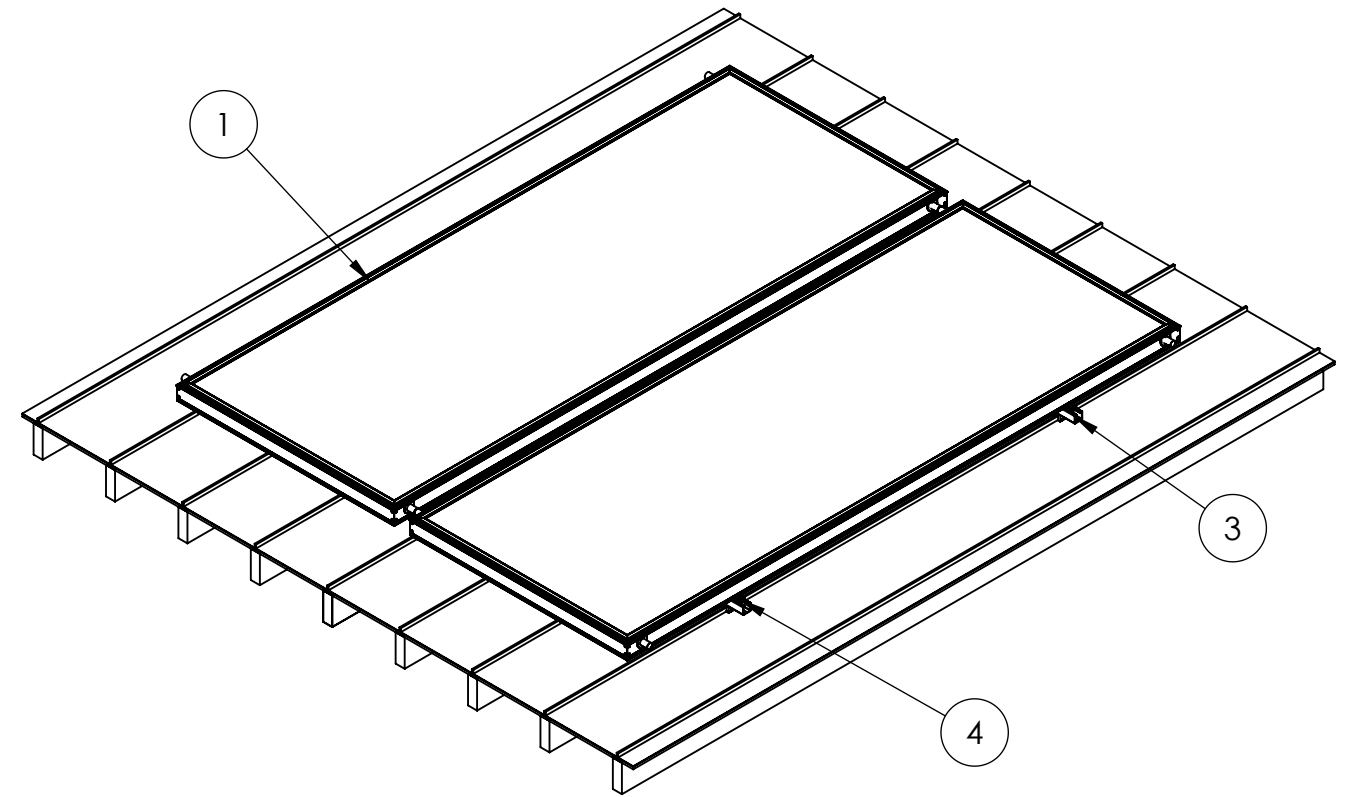

ITEM NO.	PART NUMBER	DESCRIPTION	Default/ QTY.
1	EP/EC/US-40	SUNEARTH EMPIRE CLASS COLLECTOR	2
2	S-5-U	STANDING SEAM CLAMP	8
4	C-SSN	3/8" STRUT NUT ASSEMBLY WITH CLIP	8
3	10070-158-104.5-BA	104.5 1-5/8 IN BA SOLARSTRUT	2

REVISIONS		
ECR NO.	REV	DESCRIPTION
	A	INITIAL

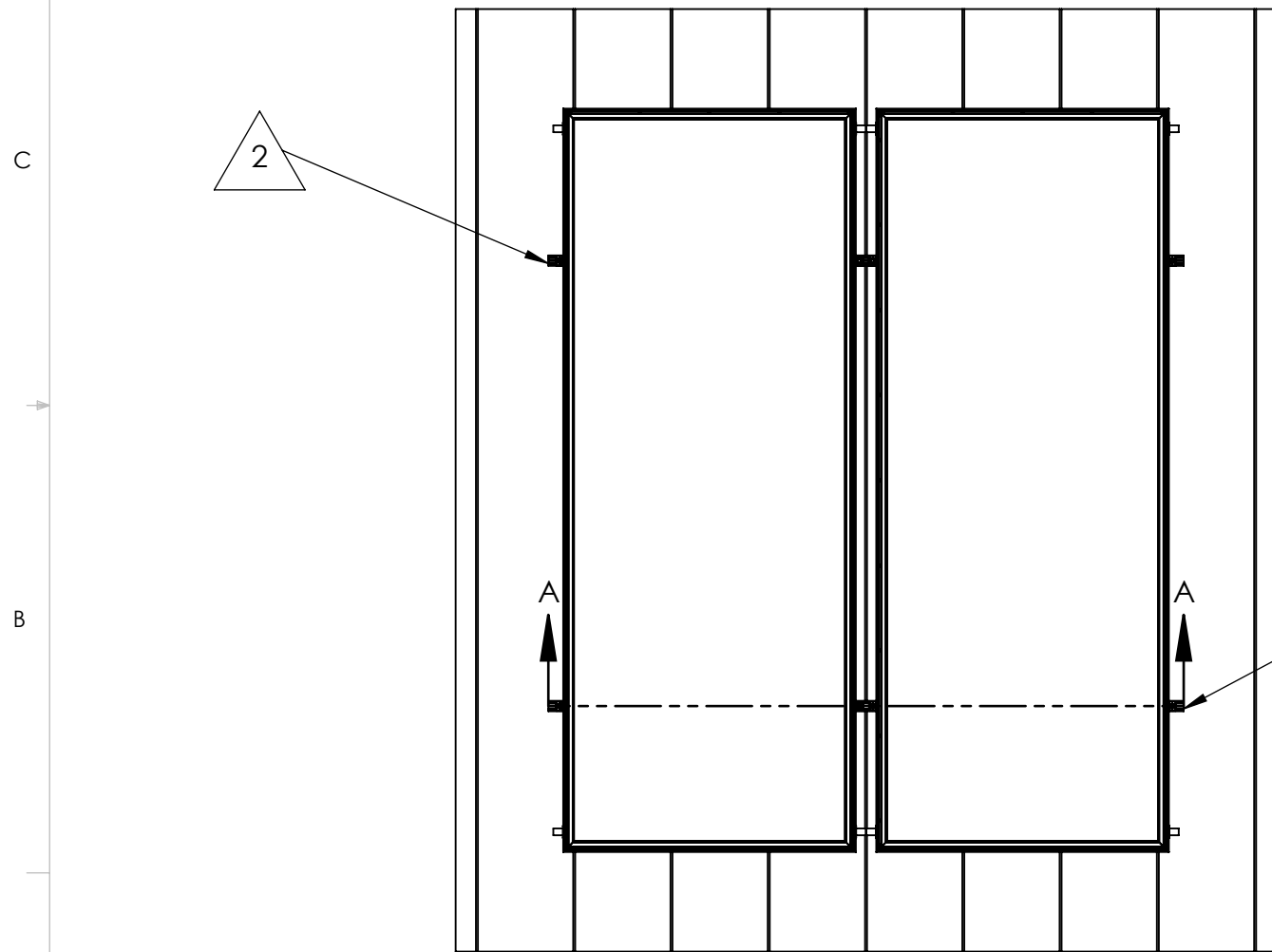

NOTE:  
 1. DRAWING SECTION VIEW A:A LOCATED ON SHEET 3
 2. SEE DRAWING SE-M-0001-A FOR STRUT MOUNTING LOCATIONS

PROPRIETARY AND CONFIDENTIAL
 THE INFORMATION CONTAINED IN THIS DRAWING IS THE SOLE PROPERTY OF <INSERT COMPANY NAME HERE>. ANY REPRODUCTION IN PART OR AS A WHOLE WITHOUT THE WRITTEN PERMISSION OF <INSERT COMPANY NAME HERE> IS PROHIBITED.

		UNLESS OTHERWISE SPECIFIED:		NAME	DATE	SUNEARTH INC. TITLE: STANDING SEAM METAL ROOF MOUNTING		
		DIMENSIONS ARE IN INCHES	DRAWN	ARC	8/10			
		TOLERANCES:	CHECKED					
		FRACTIONAL ±	ENG APPR.					
		ANGULAR: MACH ±0.5 BEND ±1.0	MFG APPR.					
		TWO PLACE DECIMAL ±0.01	Q.A.					
		THREE PLACE DECIMAL ±0.005	COMMENTS:					
		INTERPRET GEOMETRIC TOLERANCING PER:						
		MATERIAL						
NEXT ASSY	USED ON	FINISH				SIZE B	DWG. NO. SE-R-0001-A	REV A
APPLICATION		DO NOT SCALE DRAWING				SCALE: 1:30	WEIGHT:	SHEET 1 OF 3

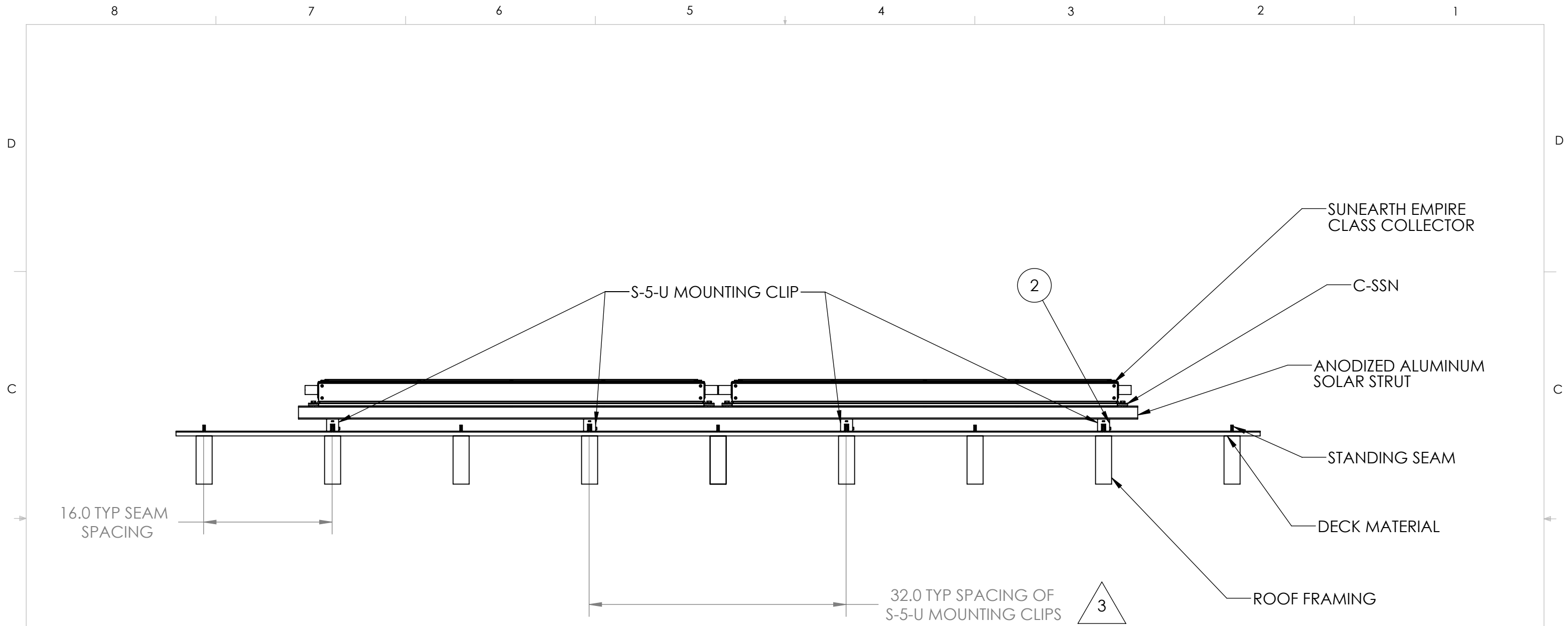

16.0 TYP SEAM SPACING

32.0 TYP SPACING OF S-5-U MOUNTING CLIPS

SUNEARTH EMPIRE CLASS COLLECTOR

C-SSN

ANODIZED ALUMINUM SOLAR STRUT

STANDING SEAM

DECK MATERIAL

ROOF FRAMING

S-5-U MOUNTING CLIP

3

NOTE:
3. CONFIRM S-5-U CLIP QUANTITY AND SPACING AGAINST LOCAL BUILDING REQUIREMENTS. VALUE GIVEN AS EXAMPLE ONLY

PROPRIETARY AND CONFIDENTIAL
THE INFORMATION CONTAINED IN THIS DRAWING IS THE SOLE PROPERTY OF <INSERT COMPANY NAME HERE>. ANY REPRODUCTION IN PART OR AS A WHOLE WITHOUT THE WRITTEN PERMISSION OF <INSERT COMPANY NAME HERE> IS PROHIBITED.

		UNLESS OTHERWISE SPECIFIED:		NAME	DATE	SUNEARTH INC.		
		DIMENSIONS ARE IN INCHES TOLERANCES: FRACTIONAL ± ANGULAR: MACH ± BEND ± TWO PLACE DECIMAL ± THREE PLACE DECIMAL ±		DRAWN	ARC			8/10
		INTERPRET GEOMETRIC TOLERANCING PER:		CHECKED		TITLE:		
		MATERIAL		ENG APPR.		STANDING SEAM METAL ROOF MOUNTING		
NEXT ASSY	USED ON	FINISH		MFG APPR.		SIZE	DWG. NO.	REV
APPLICATION		DO NOT SCALE DRAWING		Q.A.		B	SE-R-001-A	A
				COMMENTS:		SCALE: 1:12	WEIGHT:	SHEET 2 OF 3

8 7 6 5 4 3 2 1

D

D

5
C-SSN MOUNTING ASSEMBLY

1/8" GAP

SUNEARTH EMPIRE CLASS COLLECTOR

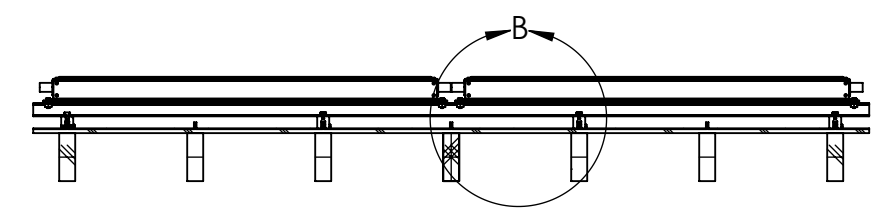

SECTION A-A
SCALE 1 : 24

S-5-U CLIP 4

ANODIZED ALUMINUM SOLAR STRUT

STANDING SEAM METAL ROOF SURFACE

DECK MATERIAL

ROOF FRAMING

C

C

B

B

DETAIL B
SCALE 1 : 3

NOTE:

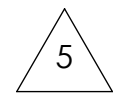
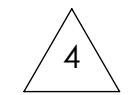

4. S-5-U (WWW.S-5.COM):
SEE MANUFACTURE SPECIFICATIONS FOR
SET SCREW TORQUE VALUES AND CLIP
STRENGTH FACTORS

5. REFERENCE SE-A-0001-A FOR C-SSN
TORQUE VALUES

PROPRIETARY AND CONFIDENTIAL
THE INFORMATION CONTAINED IN THIS
DRAWING IS THE SOLE PROPERTY OF
<INSERT COMPANY NAME HERE>. ANY
REPRODUCTION IN PART OR AS A WHOLE
WITHOUT THE WRITTEN PERMISSION OF
<INSERT COMPANY NAME HERE> IS
PROHIBITED.

		UNLESS OTHERWISE SPECIFIED:		NAME	DATE	SUNEARTH INC.	
		DIMENSIONS ARE IN INCHES TOLERANCES: FRACTIONAL ± ANGULAR: MACH ± BEND ± TWO PLACE DECIMAL ± THREE PLACE DECIMAL ±		DRAWN	ARC		
		INTERPRET GEOMETRIC TOLERANCING PER:		CHECKED		TITLE: STANDING SEAM METAL ROOF MOUNTING	
		MATERIAL		ENG APPR.		SIZE DWG. NO. REV	
NEXT ASSY	USED ON	FINISH		MFG APPR.		B SE-R-0001-A A	
APPLICATION		DO NOT SCALE DRAWING		Q.A.		SCALE: 1:12 WEIGHT: SHEET 3 OF 3	
				COMMENTS:			

8 7 6 5 4 3 2 1

A

A